

Kohler 8.5 & 12RES Installation clarifications

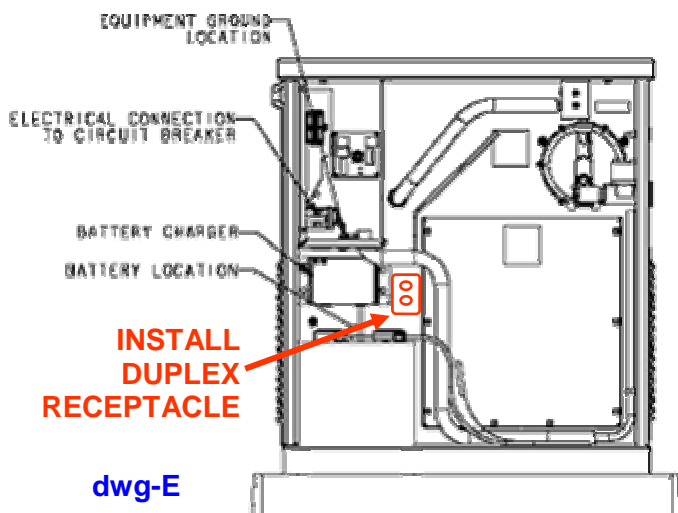

- 1) Read the Kohler Installation Manual before starting any work.
- 2) Remove end panel bolts and cover as shown in dwg-C.
- 3) Mount a box and duplex receptacle as shown in dwg-E.
- 4) Drill out pilot hole to the appropriate conduit size as shown in dwg-D.
- 5) Wire connections consist of Generator output cables, 2 #14g or 12g for the start circuit, and wiring to the new duplex receptacle (for the battery charger).

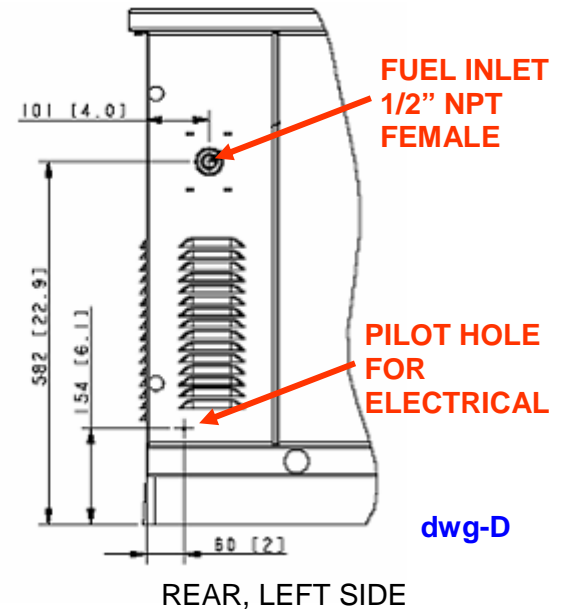
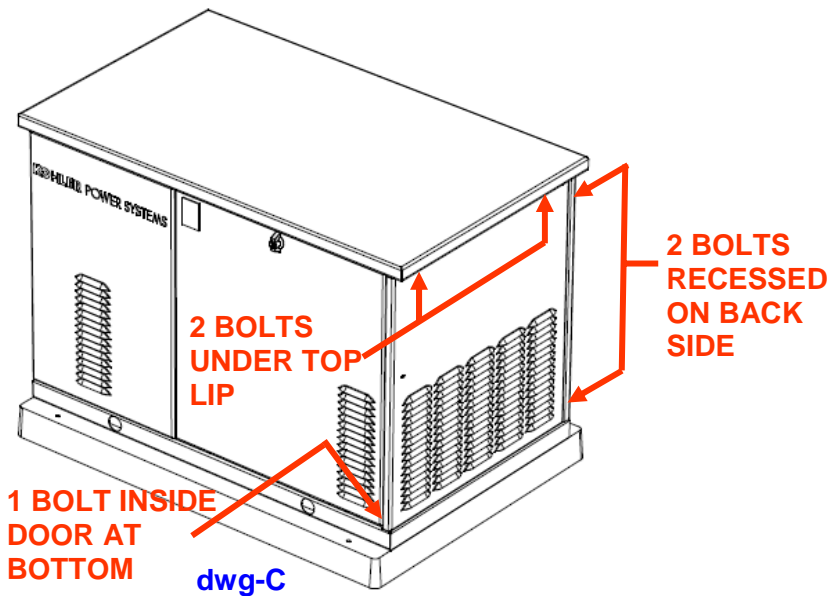
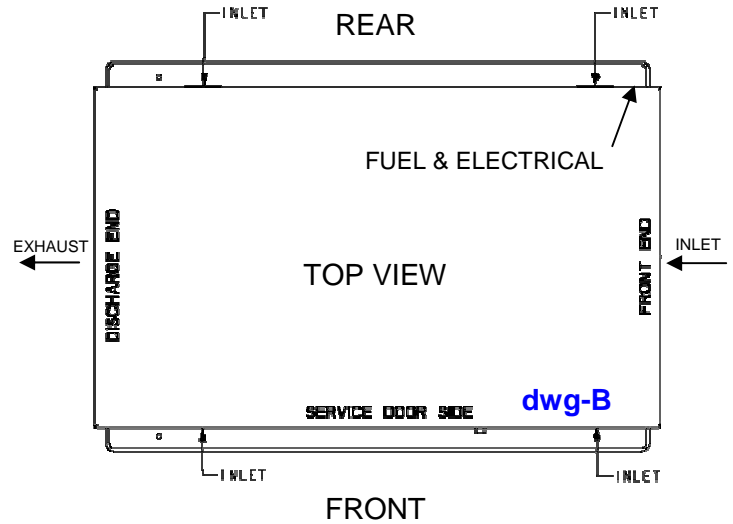
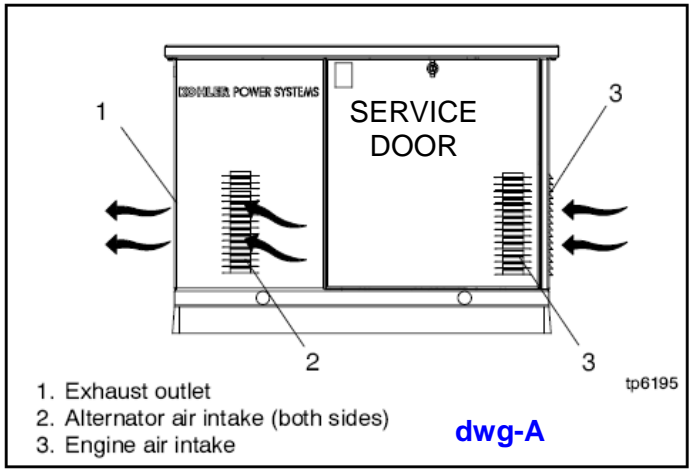